

# Rotary Cutter

RCD1884

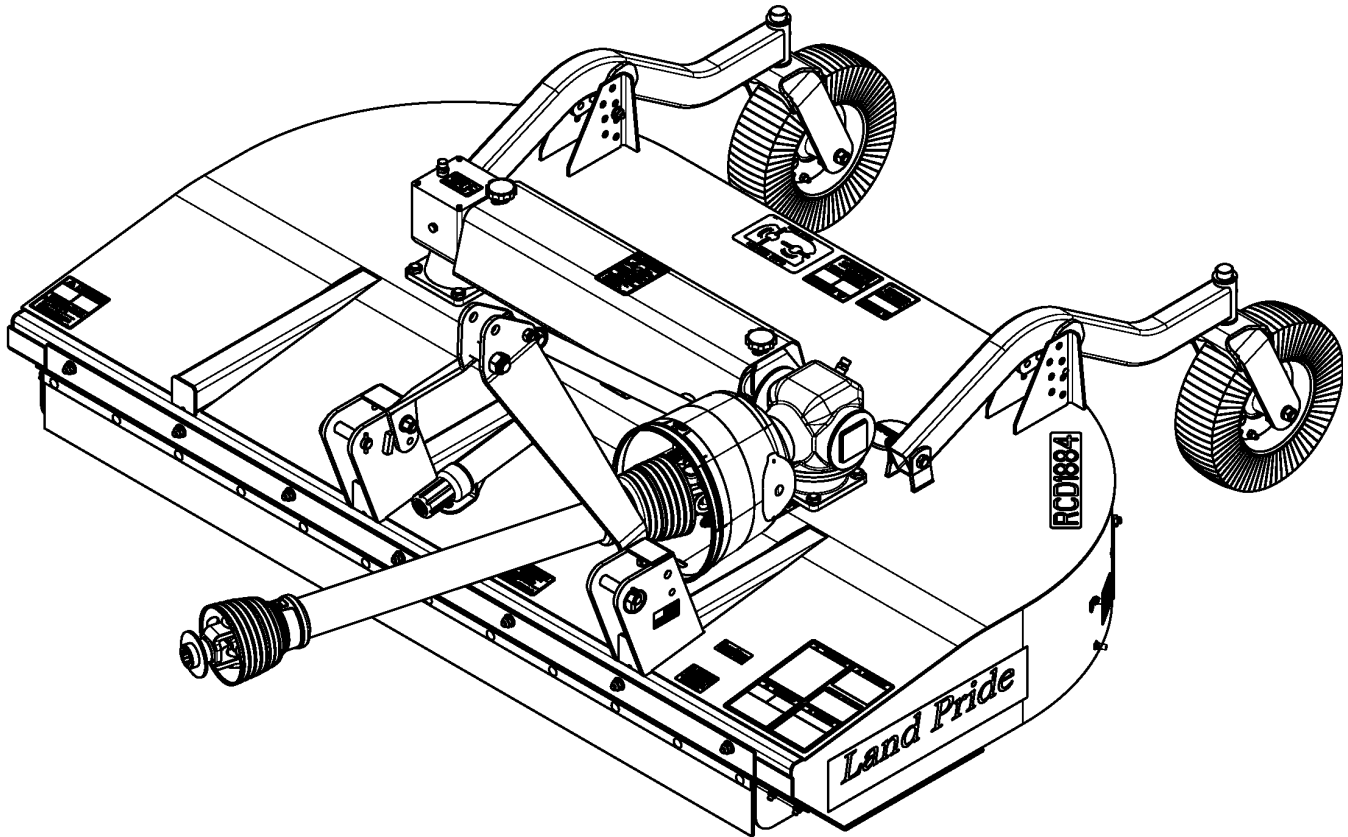

30747

## 326-355P Parts Manual



Read the Operator's Manual entirely. When you see this symbol, the subsequent instructions and warnings are serious - follow without exception. Your life and the lives of others depend on it!

© Copyright 2015 Printed 07/27/15

Cover photo may show optional equipment not supplied with standard unit.





# Table of Contents

---

<b>Section 1: Introduction.....</b>	<b>4</b>
Using This Manual.....	4
Manual Replacement Information.....	4
Manual Revisions.....	4
Touch-up Paint.....	4
Hardware Legend.....	5
Replacement Hardware.....	5
Serial Numbers.....	5
Part Number Service Coding.....	5
<b>Section 2: Decks.....</b>	<b>6</b>
Deck.....	6
Hitch & Gauge Wheel Mount.....	6
Guarding Rear Metal.....	8
<b>Section 3: Blade Drive.....</b>	<b>10</b>
Blade Carrier.....	10
Blade Drive.....	12
Driveline Intermittent (826-703C).....	14
Driveline W/ Slip Clutch (826-668C).....	16
Gearbox (826-662C).....	18
Gearbox (826-663C).....	20
<b>Section 4: Options &amp; Accessories.....</b>	<b>22</b>
Gauge Wheel Mount Dual Laminated.....	22
Gauge Wheel Mount Dual Solid.....	24
Guarding Front Rubber.....	26
Guarding Front Single Chain.....	28
Guarding Rear Metal Extended.....	30
Skid Shoe Kit.....	32
<b>Section 6: Labels.....</b>	<b>34</b>
Label Placement.....	34
<b>Part Number Index.....</b>	<b>36</b>

© Copyright 2015. All rights reserved.

Land Pride provides this publication “as is” without warranty of any kind, either expressed or implied. While every precaution has been taken in the preparation of this manual, Land Pride assumes no responsibility for errors or omissions. Neither is any liability assumed for damages resulting from the use of the information contained herein. Land Pride reserves the right to revise and improve its products as it sees fit. This publication describes the state of this product at the time of its publication, and may not reflect the product in the future. The illustrations in this manual are not intended for safe and proper assembly or disassembly of equipment. The illustrations are intended for ordering parts only.

Land Pride is registered trademark.

All other brands and product names are trademarks or registered trademarks of their respective holders.

*Printed in the United States of America.*



## Alphabetized Table of Contents

---

<b>B</b>	
Blade Carrier.....	10
Blade Drive.....	12
<b>D</b>	
Deck, Hitch & Gauge Wheel Mount.....	6
Driveline Intermittent (826-703C).....	14
Driveline W/ Slip Clutch (826-668C).....	16
<b>G</b>	
Gauge Wheel Mount Dual Laminated.....	22
Gauge Wheel Mount Dual Solid.....	24
Gearbox (826-662C).....	18
Gearbox (826-663C).....	20
Guarding Front Rubber.....	26
Guarding Front Single Chain.....	28
Guarding Rear Metal.....	8
Guarding Rear Metal Extended.....	30
<b>L</b>	
Label Placement.....	34
<b>S</b>	
Skid Shoe Kit.....	32

# General Information

## Using This Manual

This manual is divided into sections. The first section contains General Information. The remaining sections divide the machine into segments (i.e. Frames, Drives, Hydraulics, etc.) which illustrate and list all parts. A Parts Number Index is located at the back of the book.

The Land Pride parts in this manual are specially designed for this machine and should be replaced with Land Pride parts only.

The information in this manual is current at time of printing. Some parts may change to assure top performance.

Right-hand and left-hand as used in this manual are determined by facing the direction the machine will travel while in use.

Below is an example of two facing pages from a parts manual. Familiarize yourself with the type of information contained on these pages.

## Manual Replacement Information

Replacement manuals are available. Refer to our website at [www.landpride.com](http://www.landpride.com) or e-mail us at [lit@landpride.com](mailto:lit@landpride.com) for additional information. Our website continues to provide the most up-to-date manuals available.

## Touch-up Paint

Repaint parts where paint is worn or scratched to prevent rust. Aerosol cans and touch-up bottles with brush applicator are available through your local dealer. Land Pride color descriptions and part numbers are listed below. Also available are quart and gallon size paints. Add QT or GL to end of the Aerosol P/N.

Color	Product*	Aerosol	Touch-Up
Gloss Black	LP	821-032C	821-032CTU
Beige	LP	821-011C	821-011CTU
Green	SLP	821-058C	821-058CTU
Orange	SLP	821-066C	821-066CTU
Red	SLP	821-054C	821-054CTU
Blue	SLP	821-067C	821-067CTU

Notes:

- \* LP = All Land Pride Products
- SLP = Select Land Pride Products that are available in optional Green, Orange and Red.

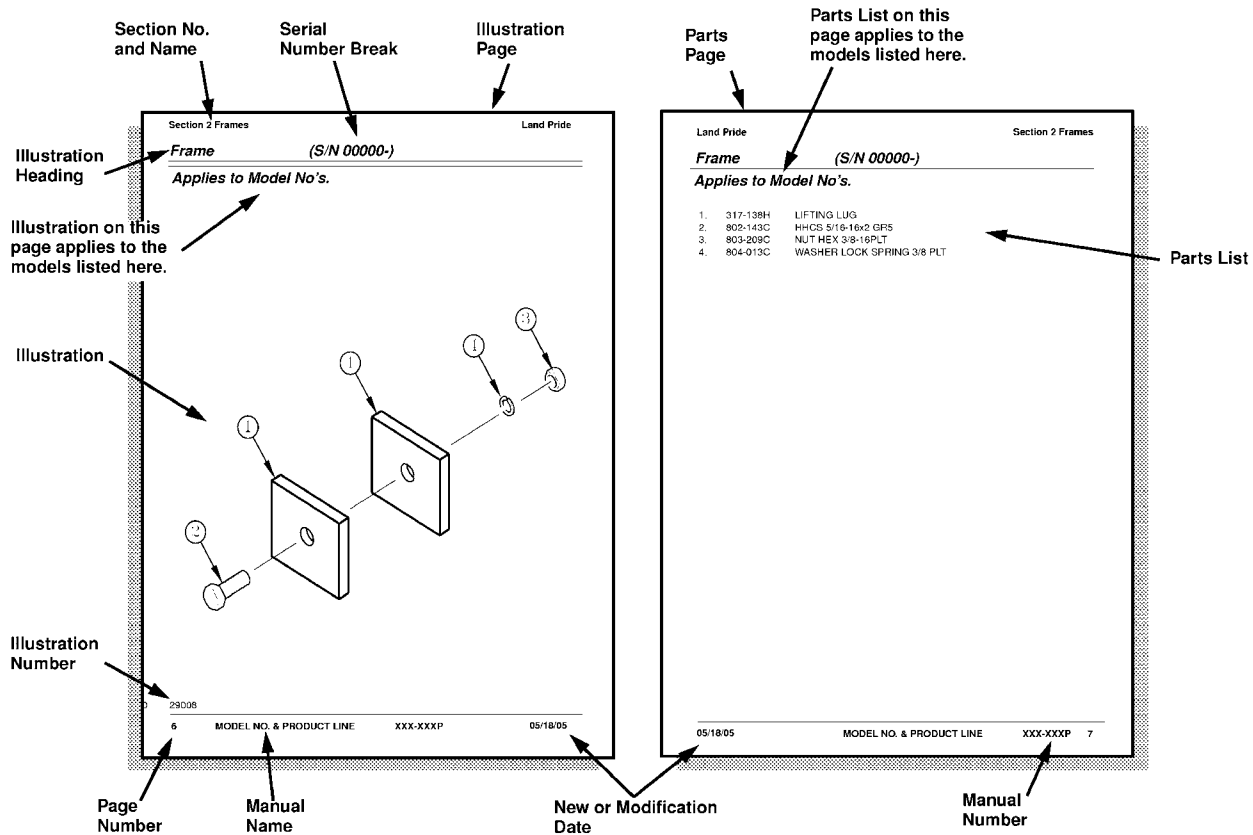

## General Information

### Hardware Legend

<b>AR</b>	As Required
<b>BLADE</b>	Blade Bolt
<b>C</b>	Cap Screw
<b>CP</b>	Cotter Pin
<b>CPHSSS</b>	Cup Point Hex Socket Set Screw
<b>CPSHSS</b>	Cup Point Square Head Set Screw
<b>CPSQHSS</b>	Cup Point Square Head Set Screw
<b>CRFCHMS3</b>	Cross Recess Flat Countersunk Head Machine Screw
<b>CRPHMS</b>	Cross Recess Pan Head Machine Screw
<b>CRPHTF</b>	Cross Recess Pan Head Thread Forming
<b>CRRHMS</b>	Cross Recess Round Head Machine Screw
<b>CRTHMS</b>	Cross Recess Truss Head Machine Screw
<b>CSNB</b>	Countersunk Square Neck Bolt
<b>FHMS</b>	Flat Head Machine Screw
<b>FTC</b>	Full Thread Cap Screw
<b>H</b>	Hex Nut
<b>HCLN</b>	Hex Center Lock Nut
<b>HFLCS</b>	Hex Flange Lock Cap Screw
<b>HFS</b>	Hex Flange Screw
<b>HFSLN</b>	Hex Flange Serrated Lock Nut
<b>HFSS</b>	Hex Flange Serrated Screw
<b>HHCS</b>	Hex Head Cap Screw or Metric Bolt
<b>HSBHCS</b>	Hex Socket Button Head Cap Screw
<b>HSFCHCS</b>	Hex Socket Flat Countersunk Head Cap Screw
<b>HSHCS</b>	Hex Socket Head Cap Screw
<b>HSSS</b>	Hex Socket Head Screw
<b>HTLN</b>	Hex Top Lock Nut
<b>HWHCS</b>	Hex Washer Head Cap Screw

<b>HWHMS</b>	Hex Washer Head Machine Screw
<b>HXBHCS</b>	Hex Socket Button Head Cap Screw
<b>J</b>	Hex Jam Nut
<b>JIC</b>	37 Degree Tapered Thread
<b>L</b>	Helical Spring Lock Washer
<b>LUG</b>	Lug Bolt
<b>NFC</b>	National Fine Cap Screw
<b>NPSM</b>	National Pipe Straight Mechanical
<b>NPTF</b>	National Pipe Taper Fuel
<b>P</b>	Wide Plain Washer
<b>PHMS</b>	Pan Head Machine Screw
<b>PLOW</b>	Plow Bolt
<b>RHMS</b>	Round Head Machine Screw
<b>RHSNB</b>	Round Head Square Neck Bolt
<b>SCREW LEVELING</b>	Leveling Screw
<b>SCREW THUMB</b>	Thumb Screw
<b>SCREW WELD</b>	Weld Screw
<b>SFCHMS</b>	Slotted Flat Countersunk Head Machine Screw
<b>SFHMS</b>	Slotted Fillister Head Machine Screw
<b>SP</b>	Special
<b>SP SCREW</b>	Special Screw
<b>SQHSS</b>	Square Head Set Screw
<b>SRHMS</b>	Slotted Round Head Machine Screw
<b>SSS</b>	Socket Set Screw
<b>STCS</b>	Self Tapping Cap Screw
<b>STHMS</b>	Slotted Truss Head Machine Screw
<b>WHEEL</b>	Wheel Studs and Hub Long Bolts
<b>WING</b>	Wing Bolt

### Replacement Hardware

The **Hardware Legend** above lists hardware abbreviations used in the parts list. All bolts and nuts are Grade 5 unless otherwise noted. The use of improper grades of hardware can result in personal injury, damage to equipment, or loss of property.

### Colored Replacement Parts

Land Pride offers replacement parts in factory standard colors and also on select models in Green, Orange, Red and Blue. Because of the variety of colors available, special attention must be given to the part number to prevent ordering the wrong replacement part.

A suffix number corresponding to one of the colors below must be added at the end of Land Pride's part number when ordering a replacement part with that color.

- |                            |                          |
|----------------------------|--------------------------|
| <b>81 . . . . . Green</b>  | <b>83 . . . . . Red</b>  |
| <b>82 . . . . . Orange</b> | <b>84 . . . . . Blue</b> |

For example, if you are ordering a replacement part with part number 555-555C and the part you need is red, then add the suffix 83 to the end of the number to make the part number read 555-555C83. Parts ordered without a suffix number will be supplied in factory standard colors.

### Black Replacement Parts

Some parts are factory standard black and some must be special ordered black. If your part is special ordered black, a second part number with the additional suffix number 85 on the end will be available. In this situation you must order that part with the suffix number for it to be black. Parts that are factory standard black will not have the suffix number.

### Part Number Service Coding

Within the parts list some part numbers are coded for revisions and interchangeability. See notations in revision column.

### Serial Numbers

Always use the serial and model number when ordering parts. Refer to the Operator's Manual for serial number plate location.

- |                      |  |
|----------------------|--|
| (S/N 20001+)         | Includes serial numbers 20001 and above (to the latest number)   |
| (S/N 10001 to 20000) | Includes serial numbers between and including 10001 and 20000    |
| (S/N 10000-)         | Includes serial numbers 10000 and below (to the earliest number) |

# Deck, Hitch & Gauge Wheel Mount

Applies to RCD1884

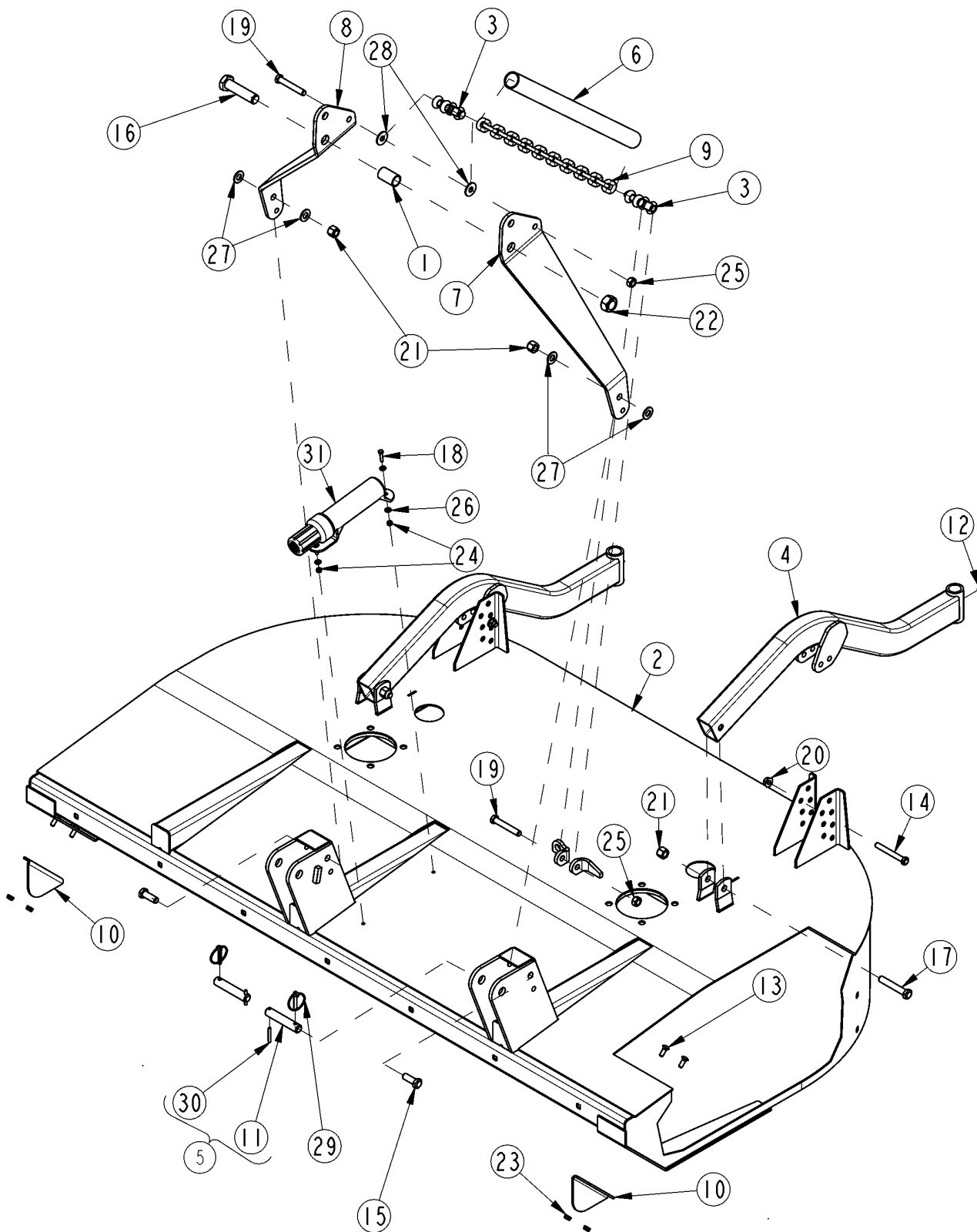

30597

**Deck, Hitch & Gauge Wheel Mount****Applies to RCD1884**

<b>Ref</b>	<b>Part No.</b>	<b>Part Description</b>	<b>Comments</b>	<b>Revision</b>
	dwg30597	Drawing Image Number		
1.	312-821D	BSHG 1 1/4ODX1 1/32IDX2 1/16LG		
2.	326-327H	RCD1884 DECK WELDMENT		
2.	326-327H81	RCD1884 DECK WELDMENT GREEN		
2.	326-327H82	RCD1884 DECK WELDMENT ORANGE		
2.	326-327H83	RCD1884 DECK WELDMENT RED		
2.	326-327H84	RCD1884 DECK WELDMENT BLUE		
3.	326-342D	CHAIN CLEVIS 7/16-1/2MID LINK		
4.	326-347H	DUAL TAILWHEEL ARM 84		
5.	326-351S	LOWER HITCH PIN		
6.	326-370D	CHAIN COVER		
7.	326-745D	RCD1884 UPPER HITCH LH		
8.	326-746D	RCD1884 UPPER HITCH RH		
9.	326-758D	FLOAT CHAIN 3/8 PROOF		
10.	326-775D	FRONT DEFLECTOR		
11.	326-803D	PIN LOWER HITCH 7/8X3.44 USBL		
12.	800-080C	GREASE ZERK 1/4-28 THD FORMING		
13.	802-015C	RHSNB 3/8-16X1 GR5		
14.	802-044C	HHCS 1/2-13X4 GR5		
15.	802-053C	HHCS 5/8-11X1 3/4 GR5		
16.	802-073C	HHCS 1-8X4 GR5		
17.	802-153C	HHCS 5/8-11X3 3/4 GR5		
18.	802-224C	HHCS 1/4-20X1 1/4 GR5		
19.	802-722C	HHCS 9/16-12X3 1/2 GR5 ZNYCR		
20.	803-037C	NUT HEX WHIZ 1/2-13 PLT		
21.	803-148C	NUT HEX NYLOCK 5/8-11 PLT		
22.	803-168C	NUT HEX TOP LOCK 1-8 PLT		
23.	803-198C	NUT HEX WHIZ 3/8-16 PLT		
24.	803-255C	NUT HEX NYLOCK 1/4-20		
25.	803-319C	NUT HEX TOP LOCK 9/16-12 ZNYCR		
26.	804-007C	WASHER FLAT 1/4 SAE PLT		
27.	804-021C	WASHER FLAT 5/8 SAE PLT		
28.	804-155C	WASHER FLAT 9/16 USS PLT		
29.	805-015C	PIN LINCH 5/16 X 1 3/4		
30.	805-041C	PIN ROLL 1/4X1 3/4		
31.	816-504C	MANUAL STORAGE CONTAINER		

# Guarding Rear Metal

Applies to RCD1884

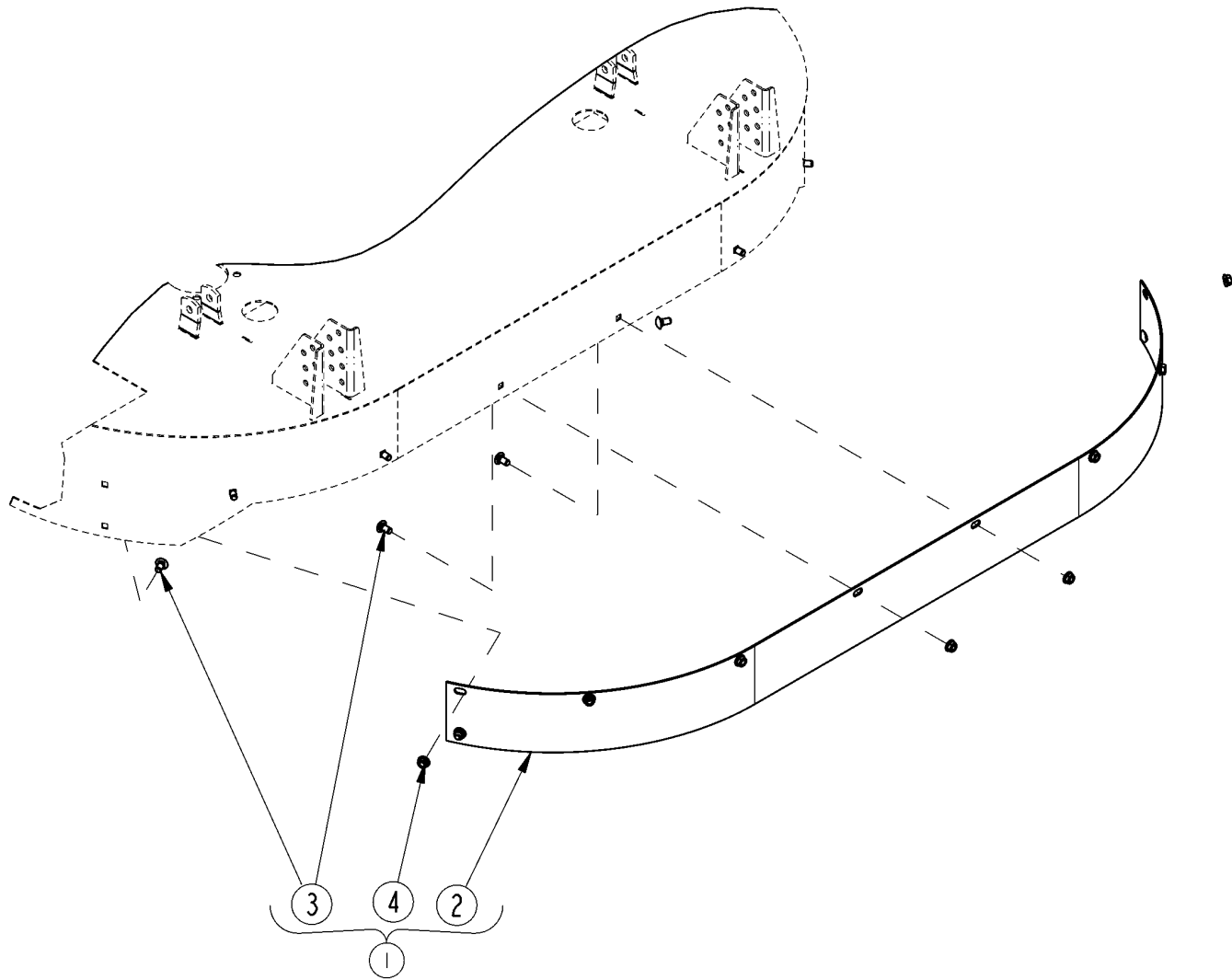

30745



***Guarding Rear Metal***

---

**Applies to RCD1884**

<b>Ref</b>	<b>Part No.</b>	<b>Part Description</b>	<b>Comments</b>	<b>Revision</b>
	dwg30745	Drawing Image Number		
1.	326-464A	REAR BAND		
2.	326-741D	REAR BAND DEFLECTOR 84		
3.	802-183C	RHSNB 1/2-13X1 GR5		
4.	803-037C	NUT HEX WHIZ 1/2-13 PLT		

# Blade Carrier

Applies to RCD1884

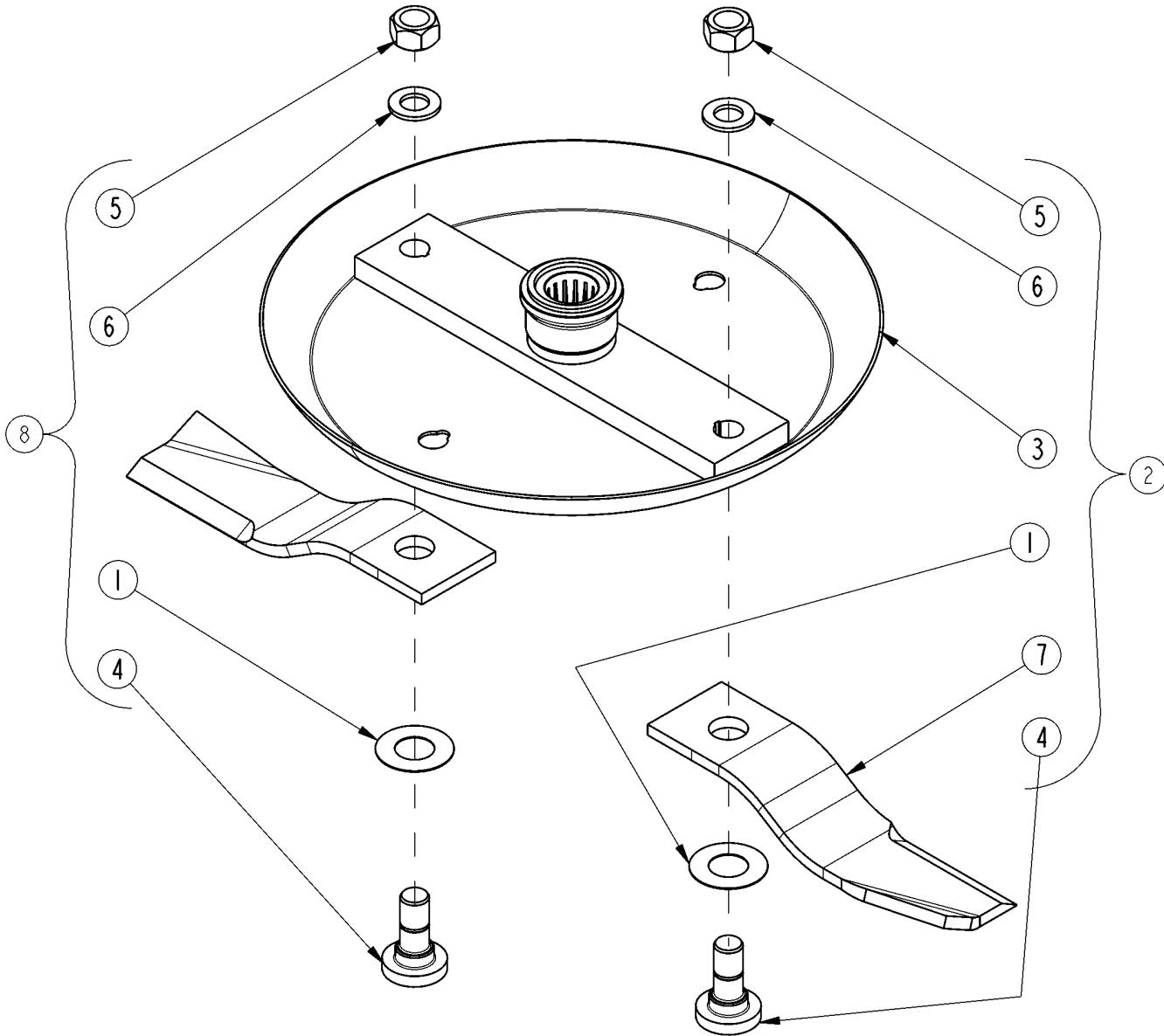

30740

**Blade Carrier****Applies to RCD1884**

<b>Ref</b>	<b>Part No.</b>	<b>Part Description</b>	<b>Comments</b>	<b>Revision</b>
	dwg30740	Drawing Image Number		
1.	312-082D	BLADE SPACER 18 GA .052 Thick	As Required S/N 776426-	
1.	312-075D	BLADE SPACER 16 GA .064 Thick	As Required S/N 776426-	
1.	312-089D	BLADE SPACER 20 GA. .04 Thick	As Required S/N 776426-	
1.	312-808D	BLADE SPACER 24GA .03 Thick	As Required S/N 776426-	
2.	N/A	RCD1884 ASSY CCW BLADE CARRIER		
3.	326-234H	RCD DISH PAN		
4.	802-277C	BLD BLT 1 1/8-12X3.44 W/.25KEY		
5.	803-170C	NUT HEX TOP LOCK 1 1/8-12 PLT.		
6.	804-147C	WASHER FLAT 1 HARD ASTM436 PN		
7.	820-501C	CUTTER BLADE 1/2X4X16 CCW	S/N 796184+	
7.	820-443C	CUTTER BLADE 1/2X4X16 CCW	S/N 796183-	
8.	318-586A	BLADE BOLT KIT		

# Blade Drive

Applies to RCD1884

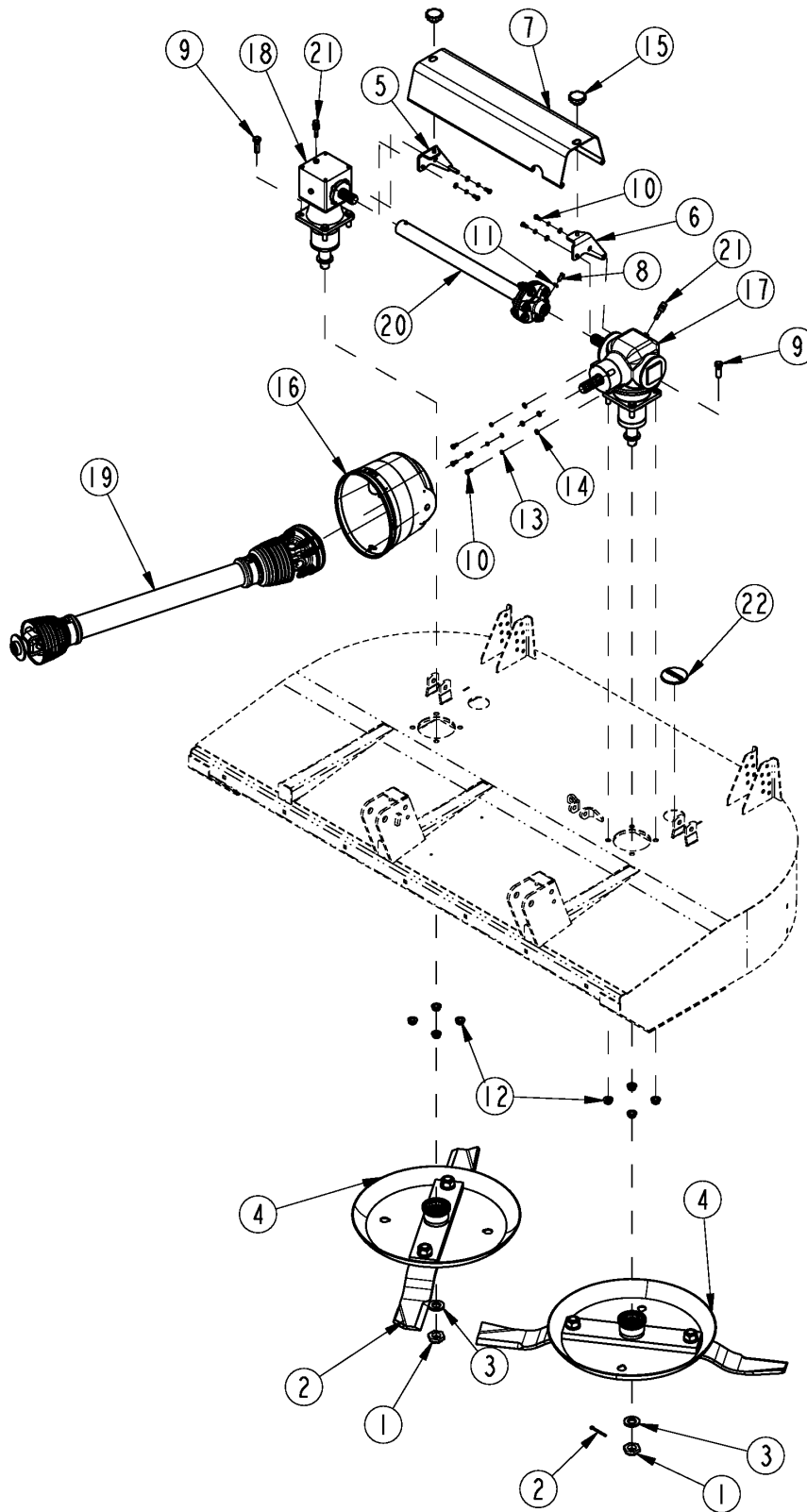

30743

**Blade Drive****Applies to RCD1884**

<b>Ref</b>	<b>Part No.</b>	<b>Part Description</b>	<b>Comments</b>	<b>Revision</b>
	dwg30743	Drawing Image Number		
1.	8.2.2.00555	CO NUT, CASTLE M30 X 2		
2.	8.4.7.00146	CO COTTER PIN B6 X 60		
3.	0.139.7101.00	CO BLANK WASHER		
4.		SEE BLADE CARRIER FOR COMPONENTS		
5.	326-467H	SHIELD BRACKET WELDMENT		
6.	326-468H	SHIELD BRACKET WELDMENT		
7.	326-872D	OUTER SHIELD		
8.	801-007C	SCREW SET SQ HD 3/8-16X7/8 PLT		
9.	802-055C	HHCS 5/8-11X2 GR5		
10.	802-314C	HHCS M8X1.25X20 GR8.8		
11.	803-012C	NUT HEX JAM 3/8-16 PLT		
12.	803-263C	NUT HEX FLANGE LOCK 5/8-11 PLT		
13.	804-157C	WASHER SPRING LOCK M8 PLT		
14.	804-161C	WASHER FLAT M8 PLT		
15.	817-259C	KNOB 3/8-16 FEMALE THD 2 3/8OD		
16.	826-648C	LARGE SHAFT CONE W ACCESS DOOR		
17.	826-662C	TBOX 1.38-6 1.38-21 1:1.84		
18.	826-663C	GBOX RCD1884 1.38-21 1:1		
19.	826-668C	CAT 3 T40, DRVLN SLIP CLTCH		
20.	826-703C	CPLR, FLEX 1.38-21X1.38-21 2DC		
21.	826-710C	COMER BREATHER PLUG		
22.	840-273C	PLUG LP 3" ID RUBBER		

**Driveline Intermittent (826-703C)**

Applies to RCD1884

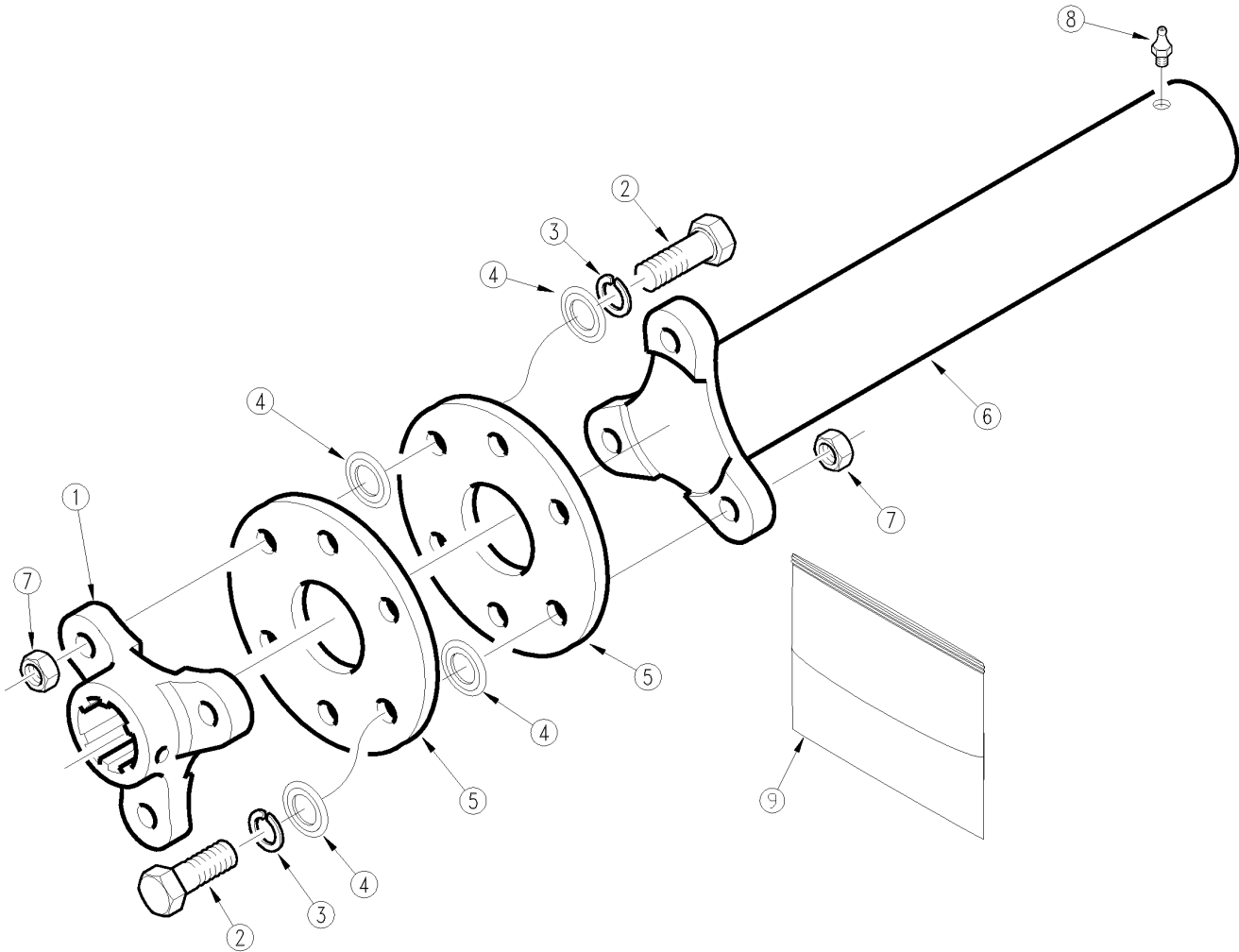

30749

***Driveline Intermittent (826-703C)***

---

**Applies to RCD1884**

<b>Ref</b>	<b>Part No.</b>	<b>Part Description</b>	<b>Comments</b>	<b>Revision</b>
	dwg30749 826-703C	Drawing Image Number CPLR, FLEX 1.38-21X1.38-21 2DC *		
1.	81010-1008	WEASLER SPIDER		
2.		HHCS 5/8-18X2 1/2 GR5	Only found in kit 9	
3.		WASHER SPECIAL	Only found in kit 9	
4.		WASHER BEADED	Only found in kit 9	
5.	21-10405	RUBBER DISC 0.6X0.375		
6.	88-25622	WEASLER SPIDER TUBE		
7.		NUT OVALOK 5/8-18 GR C	Only found in kit 9	
8.	800-001C	GREASE ZERK STRAIGHT 1/4-28		
9.	19-33302	WEASLER FLEX CPLING REPAIR KIT		

# Driveline W/ Slip Clutch (826-668C)

Applies to RCD1884

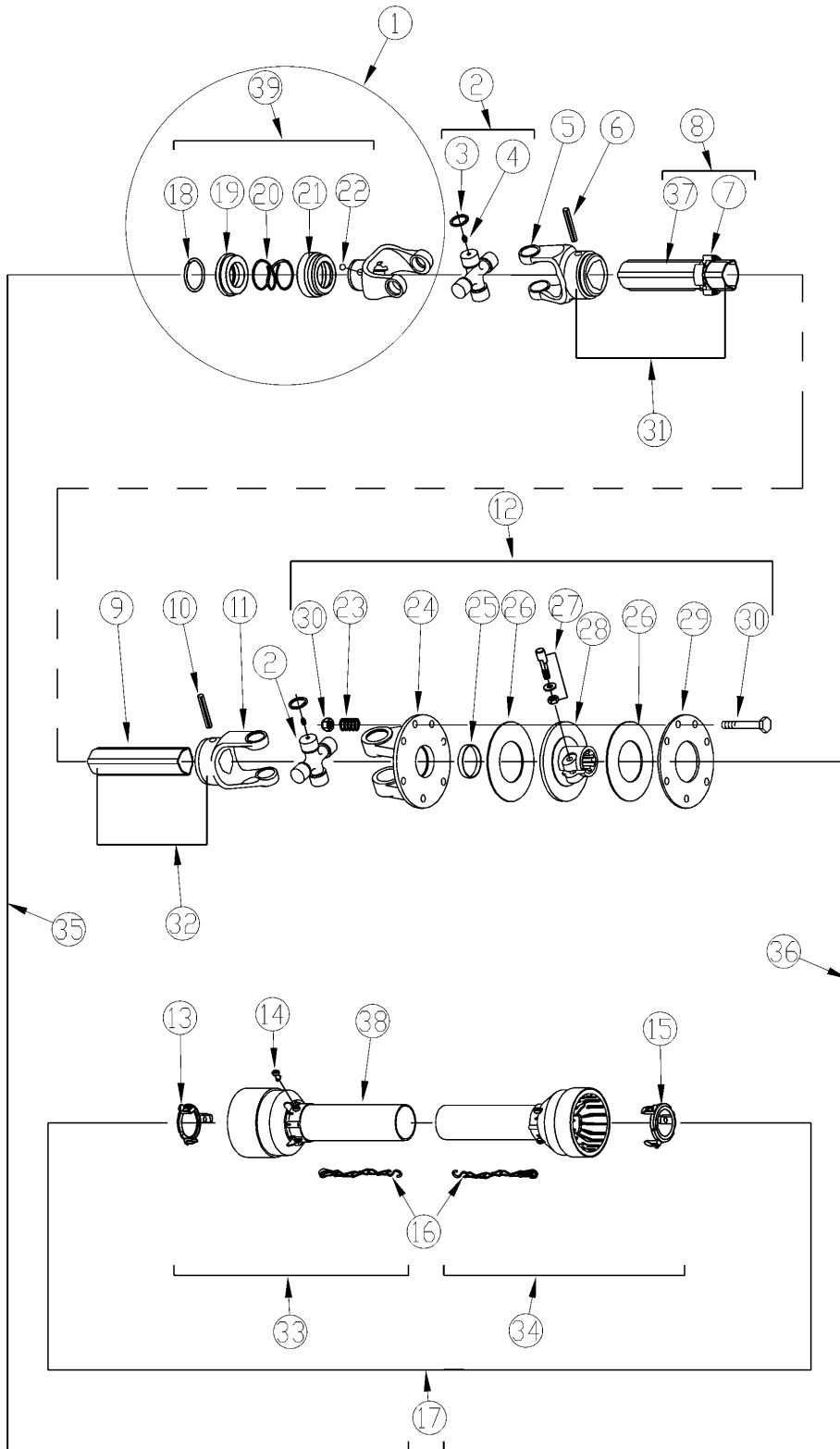

30748



**Driveline W/ Slip Clutch (826-668C)****Applies to RCD1884**

Ref	Part No.	Part Description	Comments	Revision
	dwg30748	Drawing Image Number		
	826-668C	CAT 3 X 40 T40, DRVLN SHEAR BL *		
1.	141.024.430.1	CO COMPLETE COLLAR YOKE C12		
2.	180.014.625	CO CROSS JOURNAL SET		
3.	190.000.031	CO CIRCLIP		
4.	190.000.047	CO GREASE NIPPLE		
5.	151.014.006.1	CO OUTER YOKE		
6.	190.000.014	CO ROLL PIN FOR OUTER TUBE		
7.	180.014.291	CO BUSH WITH GREASE FITTING		
8.	152.140.3310710	CO COMPLETE OUTER TUBE		
9.	153.140.165	CO INNER TUBE		
10.	190.000.012	ROLL PIN FOR INNER TUBE		
11.	151.014.007.1	CO INNER YOKE		
12.	146.241.012.1	CO COMP DISC CLUTCH F16 930 NM		
13.	180.014.233	CO GRD COLLER OUTER TUBE		
14.	180.014.240	COMER BOLT		
15.	180.014.232	CO GRD COLLER INNER		
16.	180.016.636	CO SAFETY CHAINS	S/N 946472-	
17.	142.240.4887421	COCOMP GUARD WITH INSTR MANUAL		
18.	190.000.451	COMER OUTER CIRCLIP		
19.	151.016.486	COMER SLIDING SLEEVE COLLER		
20.	180.016.487	COMER SPRING		
21.	180.016.483	COMER FIXED SLEEVE		
22.	190.000.078	COMER BALL 1/2"		
23.	180.014.022	COMER SPRING		
24.	151.014.009.1	CO FLANGED YOKE		
25.	180.015.020	COMER BUSH		
26.	180.015.019	COMER LINING RING		
27.	165.000.588	CO TAPERED PIN SET 1 3/8"		
28.	151.014.241.1	CO CLUTCH SUPPORT F16		
29.	180.015.021.1	CO PRESSURE PLATE		
30.	165.000.501	COMER NUT & BOLT M10X80		
31.	N/A	CO FEMALE TUBE YOKE WITH PIN		
32.	122.340.522.1	CO MALE TUBE WITH PIN		
33.	142.246.1927421	CO HALF FEMALE GUARD		
34.	142.247.1957421	CO HALF MALE GUARDING		
35.	123.340.355.11	CO HALF FEMALE SHAFT W GUARD		
36.	123.440.701.11	CO HALF MALE SHAFT W GUARD		
37.	190.000.098	COMER DANGER LABEL OUTER TUBE		
38.	190.000.099	COMER DANGER LABEL GUARD OUTER		
39.	165.000.628	COMER COLLOR KIT 1-3/8 YOKE		

# Gearbox (826-662C)

Applies to RCD1884

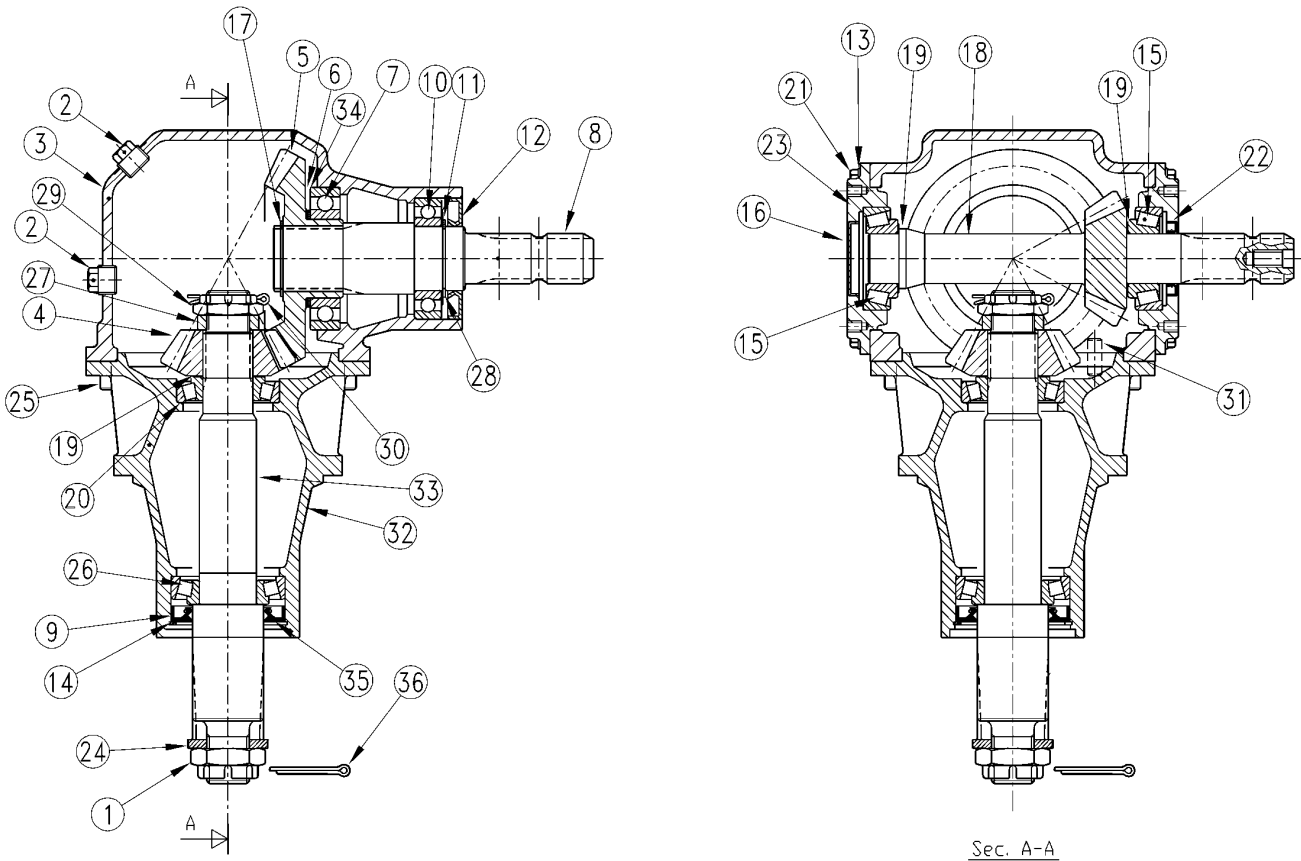

30741

**Gearbox (826-662C)****Applies to RCD1884**

Ref	Part No.	Part Description	Comments	Revision
	dwg30741	Drawing Image Number		
	826-662C	TBOX 1.38-6 1.38-21 1:1.84 *		
1.	8.2.2.00555	CO NUT, CASTLE M30 X 2		
2.	8.6.5.00203	CO PLUG 1/2" GAS		
3.	0.266.0300.00	CO CASING		
4.	0.266.6001.00	CO PINION Z13 M6.33		
5.	0.113.6001.00	CO CROWN WHEEL Z24 M6.33		
6.	0.257.7513.00	CO SHIM 55.3X67.7X1.3		
7.	N/A	CO BEARING 6211		
8.	0.266.2004.00	CO SHAFT 1 3/8" Z6		
9.	8.7.1.01929	CO OIL SEAL L 50X80X10		
10.	822-189C	BRG BALL 6209		
11.	A252.500	CO SHIM 65.3MM RTA25		
12.	8.7.3.00331	CO OIL SEAL 45 X 85 X 10 SL		
13.	8.3.7.00140	CO SPRING WASHER 8.4X13X1.2		
14.	8.5.3.00955	CO SNAP RING SB 81		
15.	8.0.9.00127	CO BRG 32207 PR2572/96		
16.	8.7.0.00693	CO CAP 52 X 7		
17.	8.5.1.00260	CO SNAP RING 46 UNI7435		
18.	0.266.6013.00	CO PINION SHAFT Z13 M6.33		
19.	A.259.500	CO ADJUST SPACER KIT, 35.3 X48		
20.	822-167C	BRG ROLLER 1.37IDX2.83OD SET		
21.	8.1.1.00083	CO HEX BOLT M8X20 GR 8.8		
22.	060127	OMNI SEAL-INPUT CR13930		
23.	0.248.1350.00	CO COVER		
24.	0.139.7101.00	CO BLANK WASHER		
25.	8.1.2.01641	CO BOLT M10X25 12.9DCRT320		
26.	822-191C	BRG ROLLER 1.57IDX3.14OD SET		
27.	0.132.7109.00	CO SPACER		
28.	8.5.1.00200	CO SNAP RING 45 UNI7435		
29.	0.132.7106.00	CO NUT M30 X 1.5		
30.	8.4.7.01111	CO COTTER PIN B4 X 50		
31.	8.4.5.01036	SPRING PIN 10 X 26		
32.	0.266.1308.00	CO EXTENSION		
33.	0.266.3205.00	CO SHAFT		
34.	A257.500	CO SHIM 67.7MM RTA25		
35.	0.266.7100.00	CO PROTECTIVE SHIELD		
36.	8.4.7.00146	CO COTTER PIN B6 X 60		

### **Gearbox (826-663C)**

Applies to RCD1884

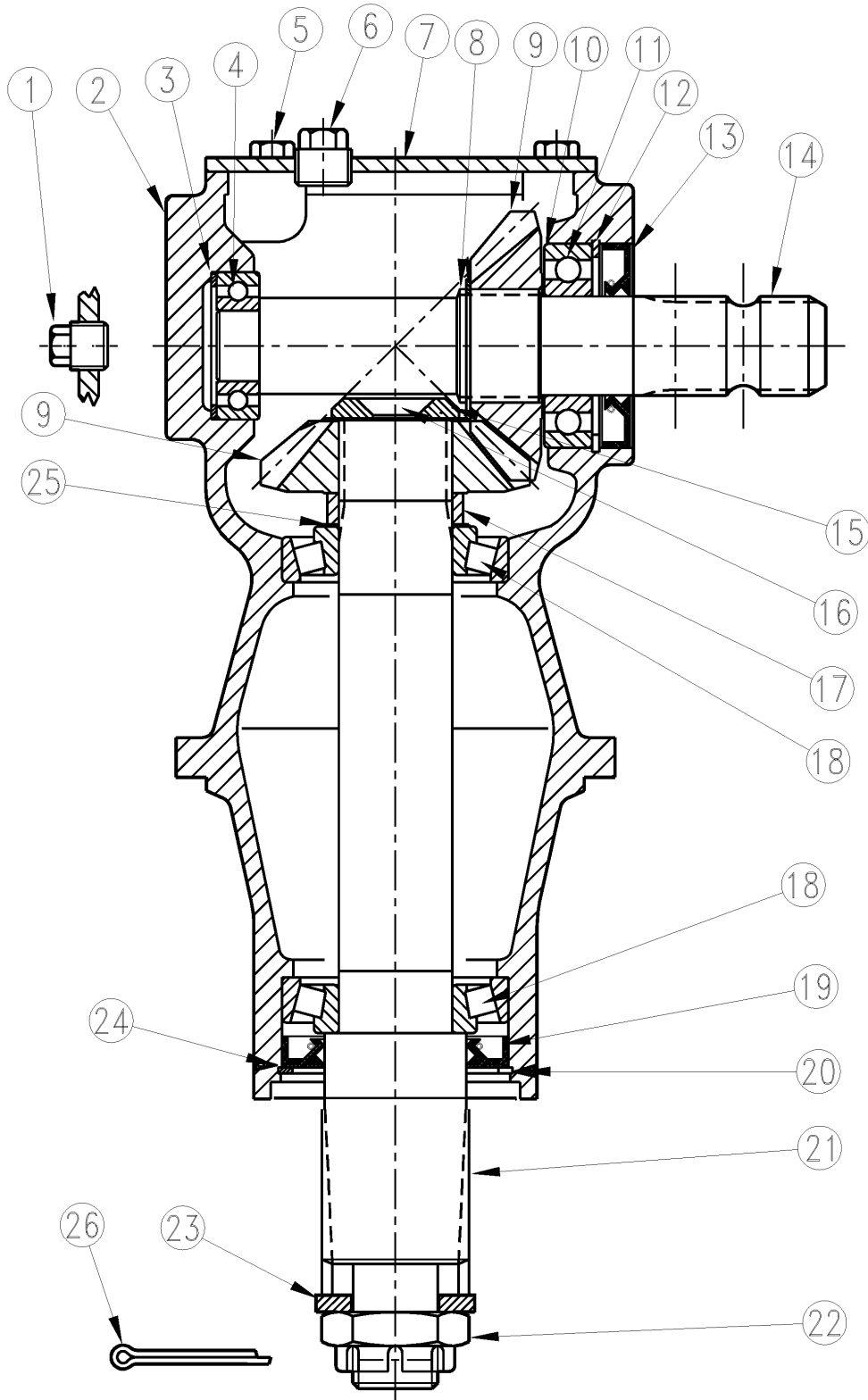

30742

**Gearbox (826-663C)****Applies to RCD1884**

Ref	Part No.	Part Description	Comments	Revision
	dwg30742	Drawing Image Number		
	826-663C	GBOX RCD1884 1.38-21 1:1 *		
1.	8.6.5.00006	CO OIL PLUG 3/8		
2.	0.129.0702.00	CO CASING		
3.	8.5.6.00953	CO SNAP RING 51X42 H3,5		
4.	8.0.1.00034	CO BRG 6205		
5.	8.1.1.00326	CO BOLT M8X16 8.8		
6.	8.6.5.00203	CO PLUG 1/2" GAS		
7.	0.129.1300.00	CO COVER		
8.	8.5.3.01002	CO SNAP RING SW 40		
9.	0.129.5003.00	CO GEAR Z18 M5		
10.	A.259.500	CO ADJUST SPACER KIT, 35.3 X48		
11.	822-166C	BRG BALL 1.37IDX2.83OD 6207		
12.	8.5.2.00131	CO SNAP RING INT 72 UN17437		
13.	8.7.1.00152	OIL SEAL, 35 X 72 X 12/10		
14.	0.129.2005.00	CO SHAFT 1 3/8" Z21		
15.	0.131.7002.00	CO BLANK WASHER		
16.	8.1.3.01644	CO BOLT M14X45 10.9		
17.	0.131.7101.00	CO SPACER		
18.	822-191C	BRG ROLLER 1.57IDX3.14OD SET		
19.	8.7.1.01929	CO OIL SEAL L 50X80X10		
20.	8.5.3.00955	CO SNAP RING SB 81		
21.	0.129.3001.00	CO SHAFT		
22.	8.2.2.00555	CO NUT, CASTLE M30 X 2		
23.	0.139.7101.00	CO BLANK WASHER		
24.	0.266.7100.00	CO PROTECTIVE SHIELD		
25.	A244.501	CO SHIM 40.3 X 51.5 826-067C		
26.	8.4.7.00146	CO COTTER PIN B6 X 60		

# Gauge Wheel Mount Dual Laminated

Applies to RCD1884

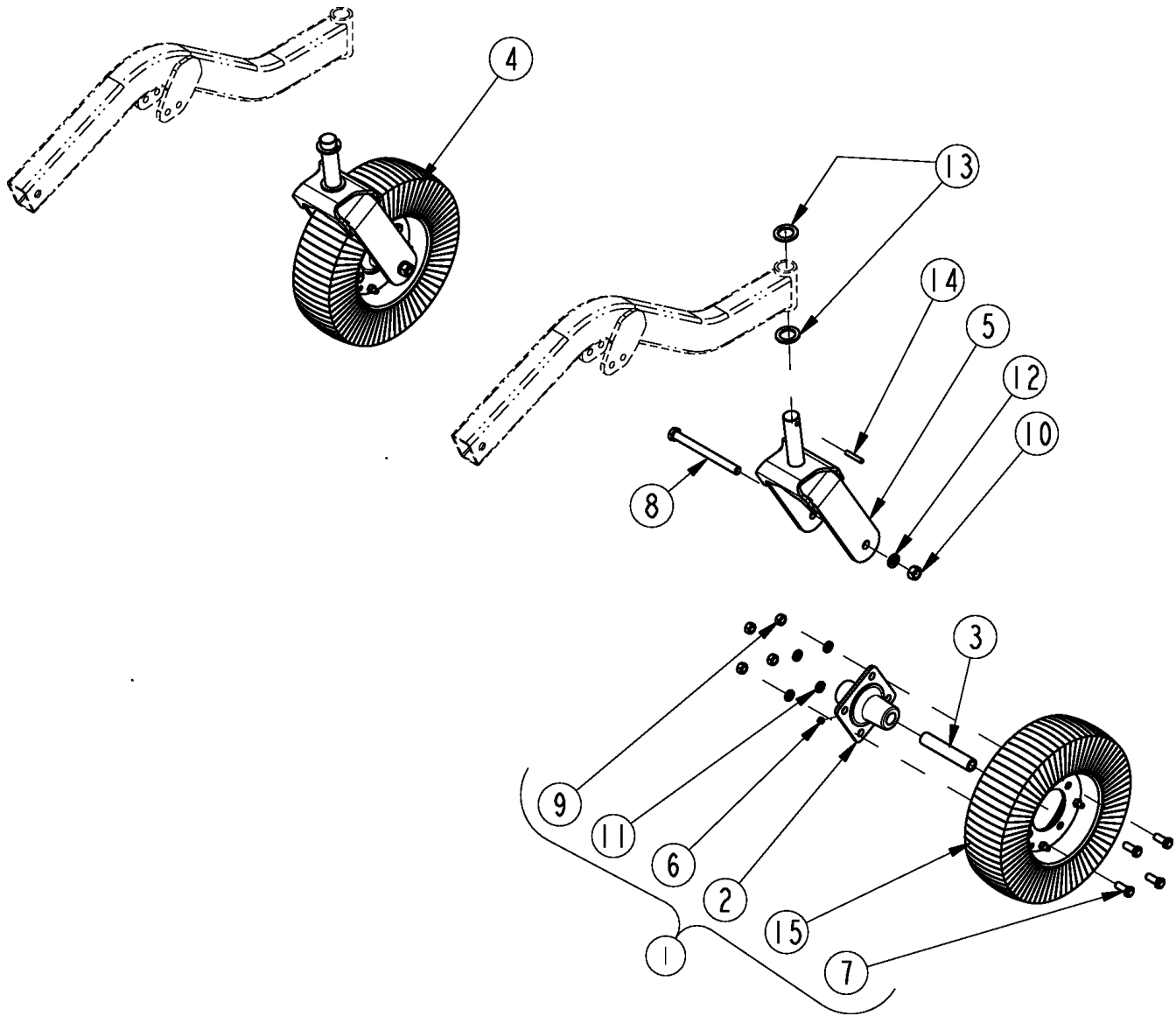

30599

**Gauge Wheel Mount Dual Laminated****Applies to RCD1884**

<b>Ref</b>	<b>Part No.</b>	<b>Part Description</b>	<b>Comments</b>	<b>Revision</b>
	dwg30599	Drawing Image Number		
	326-343A	RCD1884 LAMINATED TAILWHEEL *		
1.	312-008S	TAILWHEEL HUB AND WHEEL ASSY		
2.	312-020D	TAILWHEEL HUB		
3.	312-021D	TUBE 1 OD X 5/32 WL X 5 3/8 LG		
4.	312-553A	LAMINATED TIRE/WHEEL & YOKE		
5.	326-668H	WMT, TAILWHEEL	S/N 810210+	
5.	312-561H	RPBY 326-668H	S/N 810209-	
6.	09-014	ZERK, M8X1 GREASE	S/N 674390+	
6.	800-080C	GREASE ZERK 1/4-28 THD FORMING	S/N 674389-	
7.	802-034C	HHCS 1/2-13X1 1/4 GR5		
8.	802-262C	HHCS 5/8-11X7 GR5		
9.	803-020C	NUT HEX 1/2-13 PLT		
10.	803-021C	NUT HEX 5/8-11 PLT		
11.	804-015C	WASHER LOCK SPRING 1/2 PLT		
12.	804-022C	WASHER LOCK SPRING 5/8 PLT		
13.	804-062C	WASHER MACH 1.88 X 1.25 X 10GA		
14.	805-177C	PIN ROLL 5/16 X 1 3/4 PLT		
15.	814-058C	TIRE & WHEEL LAMINATED 4.0 X 8		

# Gauge Wheel Mount Dual Solid

Applies to RCD1884

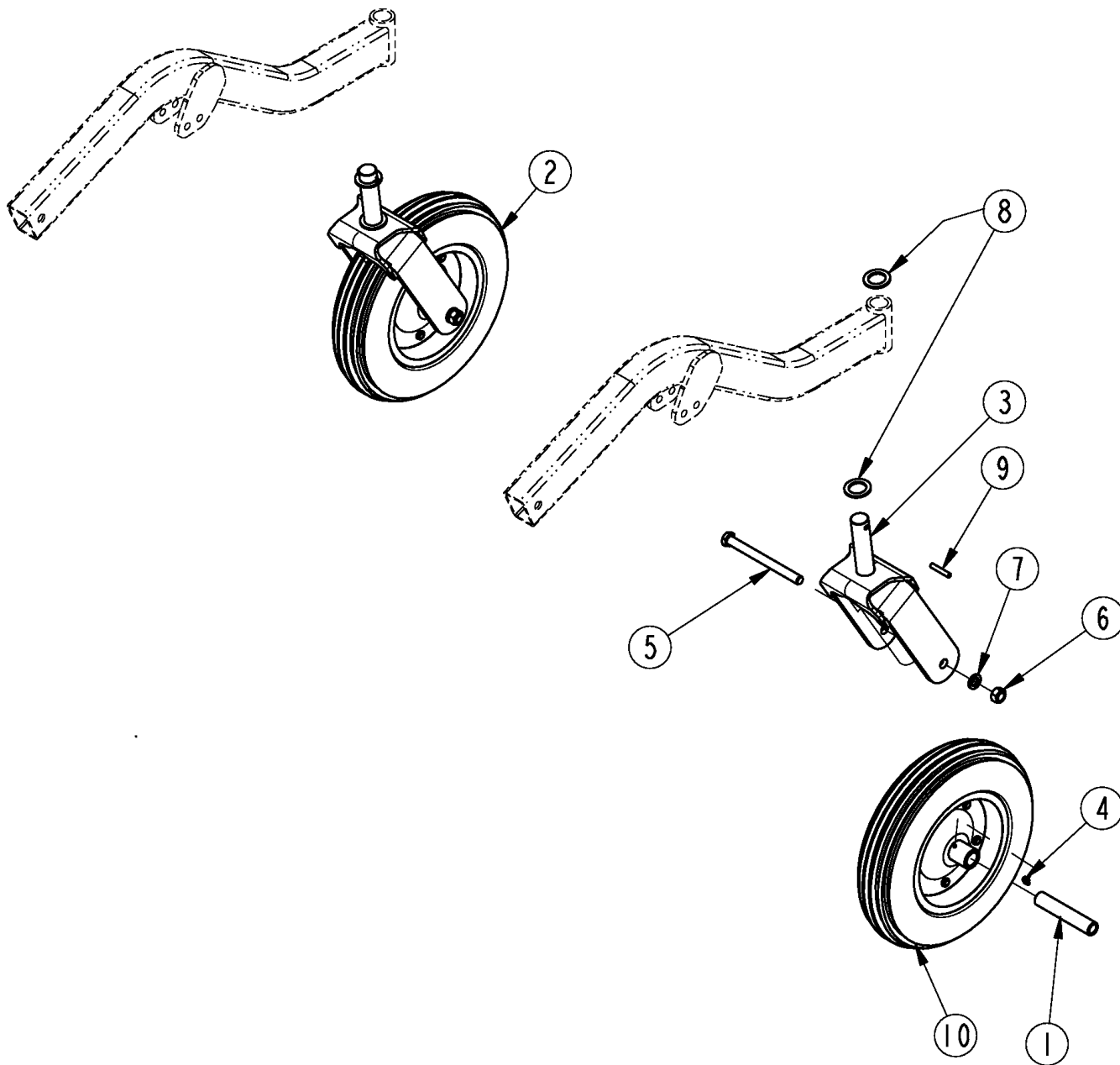

30600



## **Gauge Wheel Mount Dual Solid**

### **Applies to RCD1884**

<b>Ref</b>	<b>Part No.</b>	<b>Part Description</b>	<b>Comments</b>	<b>Revision</b>
	dwg30600	Drawing Image Number		
	326-344A	RCD1884 SOLID TAILWHEEL *		
1.	312-021D	TUBE 1 OD X 5/32 WL X 5 3/8 LG		
2.	312-554A	RUBBER TIRE/WHEEL & YOKE		
3.	326-668H	WMT, TAILWHEEL	S/N 810210+	
3.	312-561H	RPBY 326-668H	S/N 810209-	
4.	800-316C	GREASE ZERK 1/4-28 X 45-DEG LG		
5.	802-262C	HHCS 5/8-11X7 GR5		
6.	803-021C	NUT HEX 5/8-11 PLT		
7.	804-022C	WASHER LOCK SPRING 5/8 PLT		
8.	804-062C	WASHER MACH 1.88 X 1.25 X 10GA		
9.	805-177C	PIN ROLL 5/16 X 1 3/4 PLT		
10.	814-065C	WHL&SOLID RBR TIRE 4 X 16		



## ***Guarding Front Rubber***

---

### **Applies to RCD1884**

<b>Ref</b>	<b>Part No.</b>	<b>Part Description</b>	<b>Comments</b>	<b>Revision</b>
	dwg30598	Drawing Image Number		
1.	326-342A	RCD1884 FRONT RUBBER GUARD		
2.	326-756D	DEFLECTOR SUPPORT FLAT 84		
3.	326-757D	FRONT DEFLECTOR BRACKET 84		
4.	802-015C	RHSNB 3/8-16X1 GR5		
5.	802-214C	RHSNB 1/2-13X1 1/4 GR5		
6.	803-037C	NUT HEX WHIZ 1/2-13 PLT		
7.	803-198C	NUT HEX WHIZ 3/8-16 PLT		
8.	816-671C	RUBBER DEFLECTOR 84		



## **Guarding Front Single Chain**

---

**Applies to RCD1884**

<b>Ref</b>	<b>Part No.</b>	<b>Part Description</b>	<b>Comments</b>	<b>Revision</b>
	dwg30744	Drawing Image Number		
1.	326-449A	FRONT SINGLE CHAIN GUARD		
2.	326-852D	FRONT SINGLE CHAIN GUARD		
3.	326-853D	ROUND ROD 1/4 X 85 5/8		
4.	802-214C	RHSNB 1/2-13X1 1/4 GR5		
5.	803-037C	NUT HEX WHIZ 1/2-13 PLT		
6.	890-341C	CHAIN WELD 5/16 PROOF X 5 LINK		

# Guarding Rear Metal Extended

Applies to RCD1884

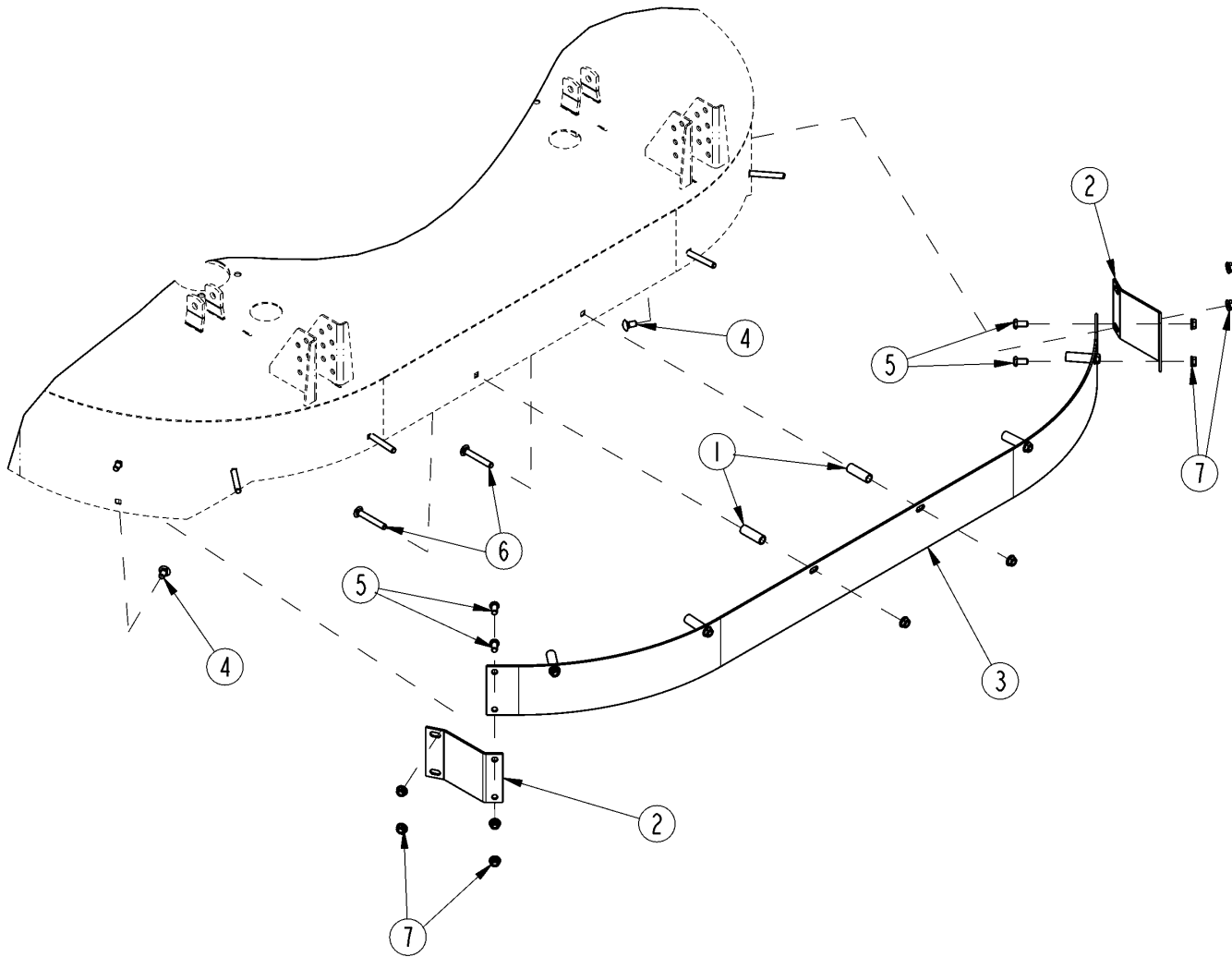

30746

## ***Guarding Rear Metal Extended***

---

### **Applies to RCD1884**

<b>Ref</b>	<b>Part No.</b>	<b>Part Description</b>	<b>Comments</b>	<b>Revision</b>
	dwg30746	Drawing Image Number		
	326-458A	RCD REAR GUARD		
		*		
1.	312-948D	DEFLECTOR SPACER		
2.	326-855D	REAR DEFLECTOR BRACKET		
3.	326-856D	REAR BAND DEFLECTOR		
4.	802-183C	RHSNB 1/2-13X1 GR5		
5.	802-258C	HHCS 1/2-13X1 GR5		
6.	802-585C	RHSNB 1/2-13X3 1/2 GR5 PLT		
7.	803-037C	NUT HEX WHIZ 1/2-13 PLT		

# Skid Shoe Kit

Applies to RCD1884

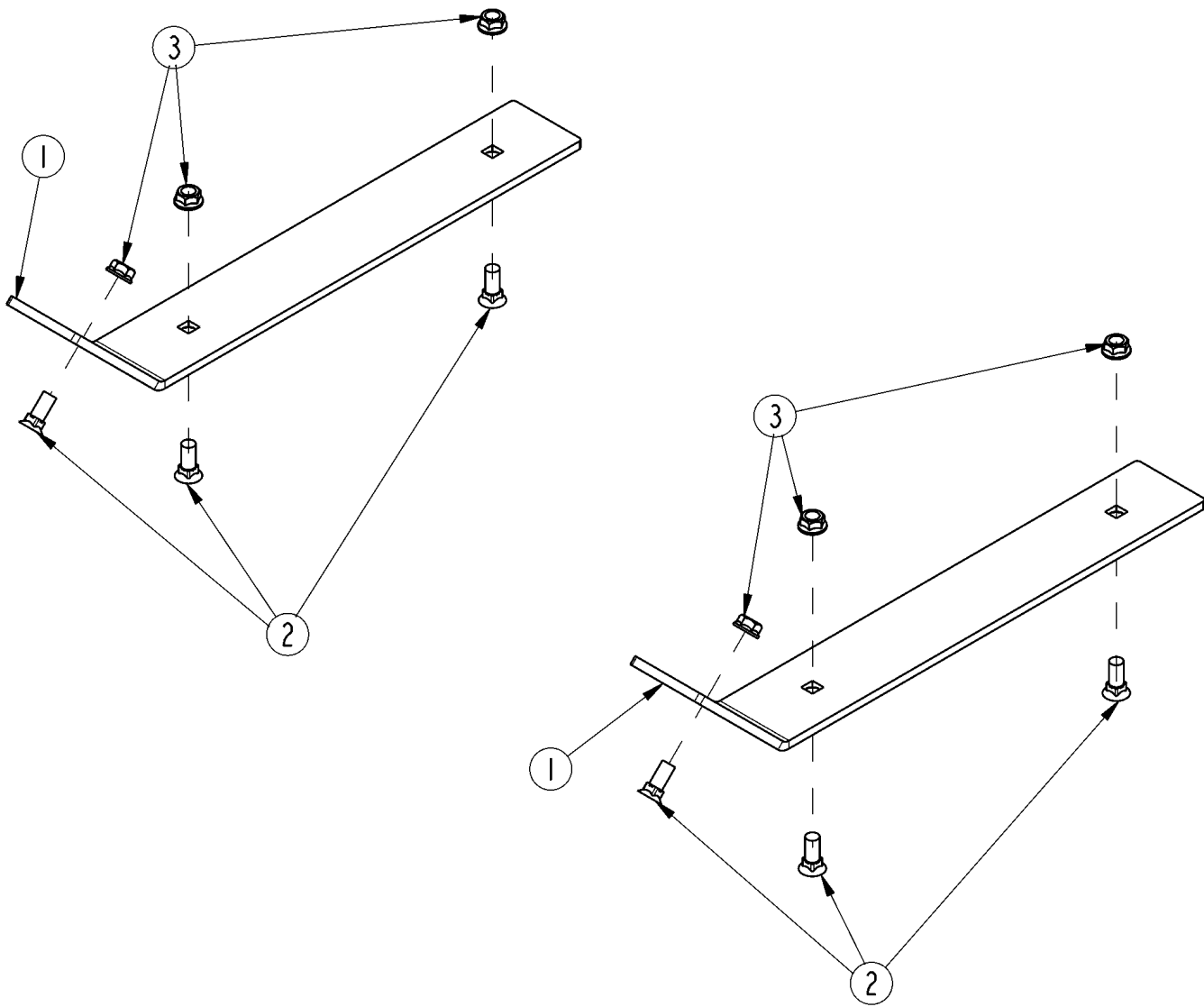

33830



## **Skid Shoe Kit**

---

### **Applies to RCD1884**

<b>Ref</b>	<b>Part No.</b>	<b>Part Description</b>	<b>Comments</b>	<b>Revision</b>
	dwg33830	Drawing Image Number		
	326-120A	SKID SHOE KIT		
		*		
1.	326-221D	SKID SHOE		
2.	802-603C	PLOW 3/8-16X1 GR5		
3.	803-198C	NUT HEX WHIZ 3/8-16 PLT		

# Label Placement

Applies to RCD1884

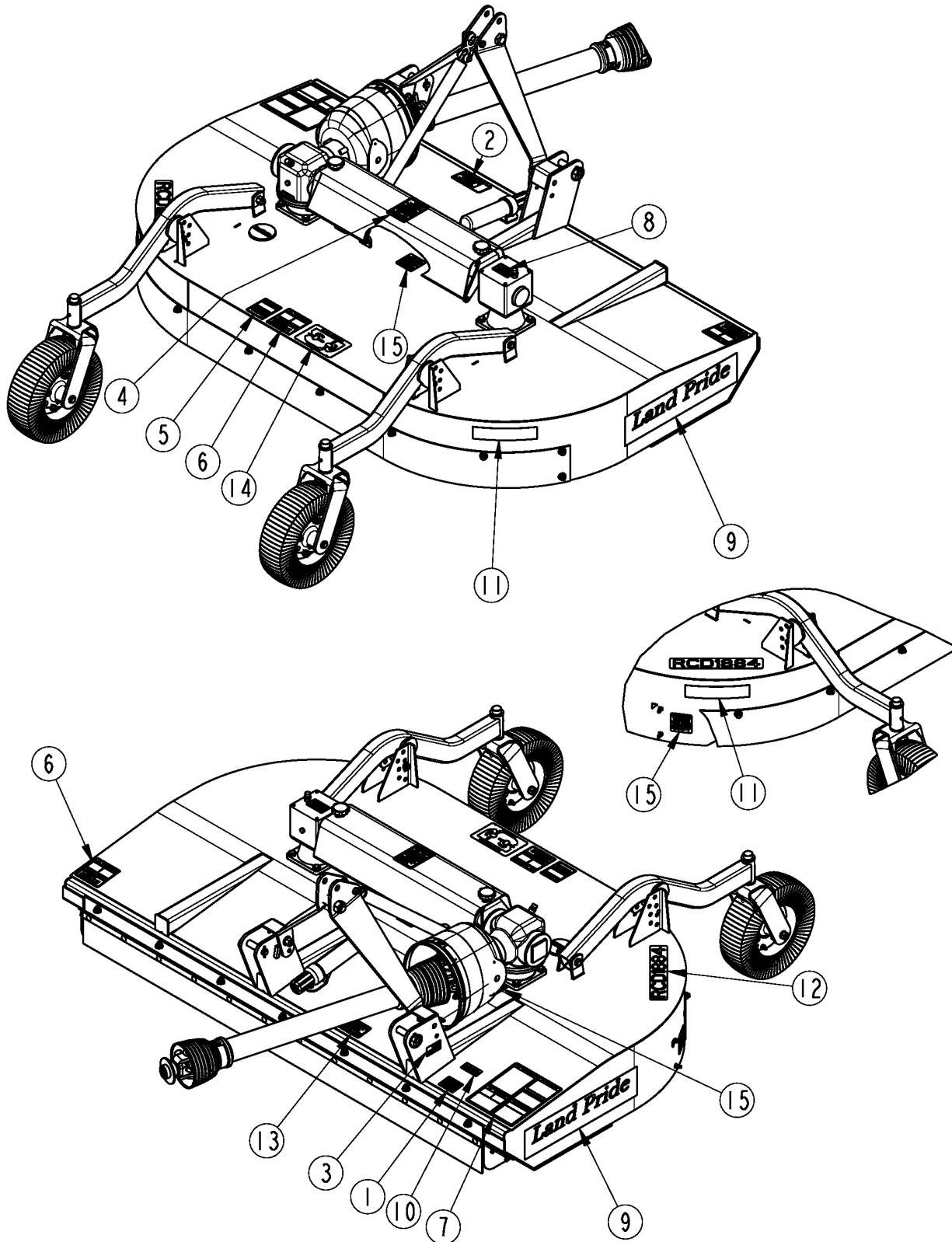

30601

***Label Placement*****Applies to RCD1884**

<b>Ref</b>	<b>Part No.</b>	<b>Part Description</b>	<b>Comments</b>	<b>Revision</b>
	818-543C	DECAL DANGER PD GUARD MISS SML		
	dwg30601	Drawing Image Number		
1.	818-130C	DECAL CAUTION 540 RPM		
2.	818-142C	DECAL DANGER PTO DRIVELINE EN		
3.	818-190C	DECAL FLAG		
4.	818-552C	DECAL DANGER PTO DRIVELINE		
5.	818-556C	DECAL DANGER THROWN OBJ CUTTER		
6.	818-564C	DECAL DANGER ROTATING BLADES		
7.	818-830C	DECAL SAFETY COMBO SUNWEST		
8.	818-862C	DECAL 5 YEAR GEARBOX WARRANTY		
9.	818-907C	DECAL LANDPRIDE 22" - BROWN	Beige Unit	
9.	838-966C	DECAL LANDPRIDE 22" BROWN/GOLD	Green, Orange & Red Unit	
10.	838-517C	DECAL QUICK HITCH SYSTEM		
11.	838-614C	DECAL REFLECTOR RED 2X9		
12.	848-624C	DECAL RCD1884 - BROWN	Beige Unit	
12.	848-625C	DECAL RCD1884 - GOLD	Green, Orange & Red Unit	
13.	848-626C	DECAL DRIVELINE 826-668C		
14.	848-681C	DECAL RCD1884 BLADE ROTATION		
15.	818-543C	DECAL DANGER PD GUARD MISS SML		



# Part Number Index

The Part Number Index is a numeric index of all part numbers included in this manual. The index shows what page(s) the part is used on.

Part Number	Page	Part Number	Page	Part Number	Page	Part Number	Page
0.113.6001.00	19	312-561H	23, 25	802-055C	13	848-626C	35
0.129.0702.00	21	312-808D	11	802-073C	7	848-681C	35
0.129.1300.00	21	312-821D	7	802-153C	7	88-25622	15
0.129.2005.00	21	312-948D	31	802-183C	9, 31	890-341C	29
0.129.3001.00	21	318-586A	11	802-214C	27, 29	A.259.500	19, 21
0.129.5003.00	21	326-120A	33	802-224C	7	A244.501	21
0.131.7002.00	21	326-221D	33	802-258C	31	A252.500	19
0.131.7101.00	21	326-234H	11	802-262C	23, 25	A257.500	19
0.132.7106.00	19	326-327H	7	802-277C	11	dwg30597	7
0.132.7109.00	19	326-327H81	7	802-314C	13	dwg30598	27
0.139.7101.00	13, 19, 21	326-327H82	7	802-585C	31	dwg30599	23
0.248.1350.00	19	326-327H83	7	802-603C	33	dwg30600	25
0.257.7513.00	19	326-327H84	7	802-722C	7	dwg30601	35
0.266.0300.00	19	326-342A	27	803-012C	13	dwg30740	11
0.266.1308.00	19	326-342D	7	803-020C	23	dwg30741	19
0.266.2004.00	19	326-343A	23	803-021C	23, 25	dwg30742	21
0.266.3205.00	19	326-344A	25	803-037C	7, 9, 27, 29, 31	dwg30743	13
0.266.6001.00	19	326-347H	7	803-148C	7	dwg30744	29
0.266.6013.00	19	326-351S	7	803-168C	7	dwg30745	9
0.266.7100.00	19, 21	326-370D	7	803-170C	11	dwg30746	31
060127	19	326-449A	29	803-198C	7, 27, 33	dwg30748	17
09-014	23	326-458A	31	803-255C	7	dwg30749	15
122.340.522.1	17	326-464A	9	803-263C	13	dwg33830	33
123.340.355.11	17	326-467H	13	803-319C	7	N/A	11, 17, 19
123.440.701.11	17	326-468H	13	804-007C	7		
141.024.430.1	17	326-668H	23, 25	804-015C	23		
142.240.4887421	17	326-741D	9	804-021C	7		
142.246.1927421	17	326-745D	7	804-022C	23, 25		
142.247.1957421	17	326-746D	7	804-062C	23, 25		
146.241.012.1	17	326-756D	27	804-147C	11		
151.014.006.1	17	326-757D	27	804-155C	7		
151.014.007.1	17	326-758D	7	804-157C	13		
151.014.009.1	17	326-775D	7	804-161C	13		
151.014.241.1	17	326-803D	7	805-015C	7		
151.016.486	17	326-852D	29	805-041C	7		
152.140.3310710	17	326-853D	29	805-177C	23, 25		
153.140.165	17	326-855D	31	81010-1008	15		
165.000.501	17	326-856D	31	814-058C	23		
165.000.588	17	326-872D	13	814-065C	25		
165.000.628	17	8.0.1.00034	21	816-504C	7		
180.014.022	17	8.0.9.00127	19	816-671C	27		
180.014.232	17	8.1.1.00083	19	817-259C	13		
180.014.233	17	8.1.1.00326	21	818-130C	35		
180.014.240	17	8.1.2.01641	19	818-142C	35		
180.014.291	17	8.1.3.01644	21	818-190C	35		
180.014.625	17	8.2.2.00555	13, 19, 21	818-543C	35		
180.015.019	17	8.3.7.00140	19	818-552C	35		
180.015.020	17	8.4.5.01036	19	818-556C	35		
180.015.021.1	17	8.4.7.00146	13, 19, 21	818-564C	35		
180.016.483	17	8.4.7.01111	19	818-830C	35		
180.016.487	17	8.5.1.00200	19	818-862C	35		
180.016.636	17	8.5.1.00260	19	818-907C	35		
19-33302	15	8.5.2.00131	21	820-443C	11		
190.000.012	17	8.5.3.00955	19, 21	820-501C	11		
190.000.014	17	8.5.3.01002	21	822-166C	21		
190.000.031	17	8.5.6.00953	21	822-167C	19		
190.000.047	17	8.6.5.00006	21	822-189C	19		
190.000.078	17	8.6.5.00203	19, 21	822-191C	19, 21		
190.000.098	17	8.7.0.00693	19	826-648C	13		
190.000.099	17	8.7.1.00152	21	826-662C	13, 19		
190.000.451	17	8.7.1.01929	19, 21	826-663C	13, 21		
21-10405	15	8.7.3.00331	19	826-668C	13, 17		
312-008S	23	800-001C	15	826-703C	13, 15		
312-020D	23	800-080C	7, 23	826-710C	13		
312-021D	23, 25	800-316C	25	838-517C	35		
312-075D	11	801-007C	13	838-614C	35		
312-082D	11	802-015C	7, 27	838-966C	35		
312-089D	11	802-034C	23	840-273C	13		
312-553A	23	802-044C	7	848-624C	35		
312-554A	25	802-053C	7	848-625C	35		

***This Page Intentionally Left Blank***



Great Plains Manufacturing, Inc.

Corporate Office: P.O. Box 5060  
Salina, Kansas 67402-5060 USA

[www.landpride.com](http://www.landpride.com)

---